

GET IT RIGHT

11. Pillars & Piers in clay brickwork

Pillar and pier architecture are considered to be synonymous terms for a large mass of masonry intended to provide additional strength and stability to a structure. In this 'Get It Right' the more common applications of these stiffening elements to free-standing walling are considered, together with their coping and capping protection.

Always ensure that the brick selected is classified as F2 durability for these exposed situations. Half brick thick walls are not advisable due to stability and exposure issues. This 'Get It Right' illustrates one brick thick walls only.

Foundations.

What is not seen is just as important as what is. Foundations will be a minimum 275mm thick and the excavation depth a minimum of 500mm. A 1:2:4 concrete mix (1 part cement: 2 parts sand: 4 parts aggregate.) (maximum aggregate size 20mm) will be adequate in most cases.

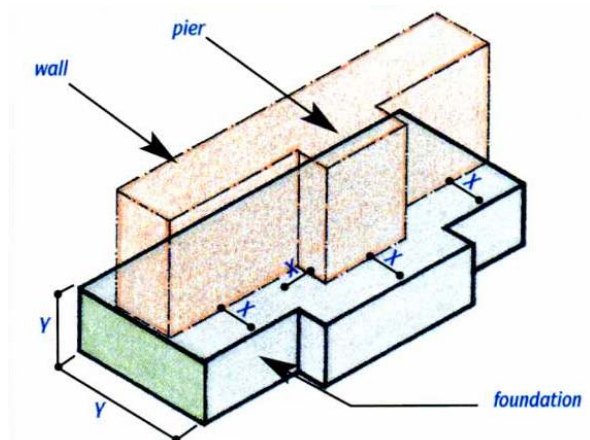

The 'y' dimensions indicated on the adjacent diagram are as the table shown for the various wall heights.

The wall to edge of foundation dimension 'x' must be retained around the pillar/pier to be constructed.

Height of Wall	Foundation Width
300	400
500	450
800	500
1000	600

Bonding

Brick bonding is an essential element of wall strength.

The bonding of bricks (the lapping of one brick partly over the bricks below), together with the correct mortar mix will give pillars and piers their strength. Where bonding is not possible, (as with 2 stretcher leafs side by side) tying together with a stainless steel reinforcement is essential to achieve a satisfactory performance.

Mortars.

Mortar is just as exposed as the brick.

Generally, and especially in the North West of England and

Scotland, we strongly recommend mortar mix 1 below ground level DPC and for copings and cappings. An exception to this recommendation would apply to 'Stock' bricks for which mix 2 should be used throughout.

Fully fill all bed and perpend joints and lay frogged bricks with frog uppermost.

Mix 1	Mix 2
1 part Portland Cement	1 part Portland Cement
$\frac{1}{4}$ part Lime	$\frac{1}{2}$ part Lime
3 parts Sand	4 $\frac{1}{2}$ parts Sand

Piers – single attached

Alternative course plans for a One and a half brick pier to a double skin wall - Stretcher bond.

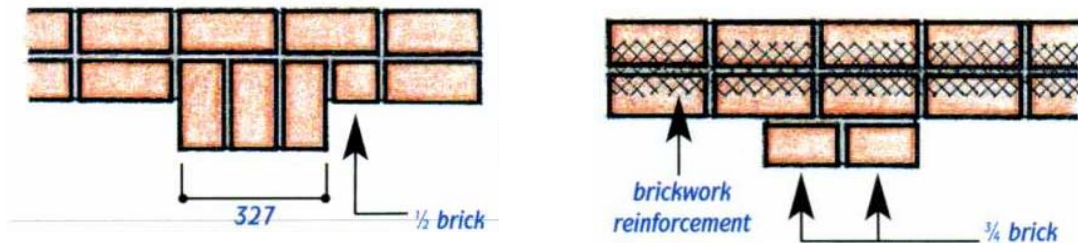

Alternative course plans for a One and a half brick pier to a one brick thick wall – English bond.

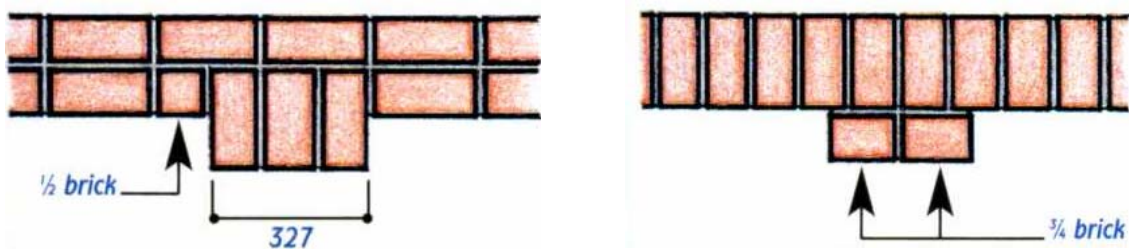

Alternative course plans for a two brick pier to a one brick thick wall – English bond.

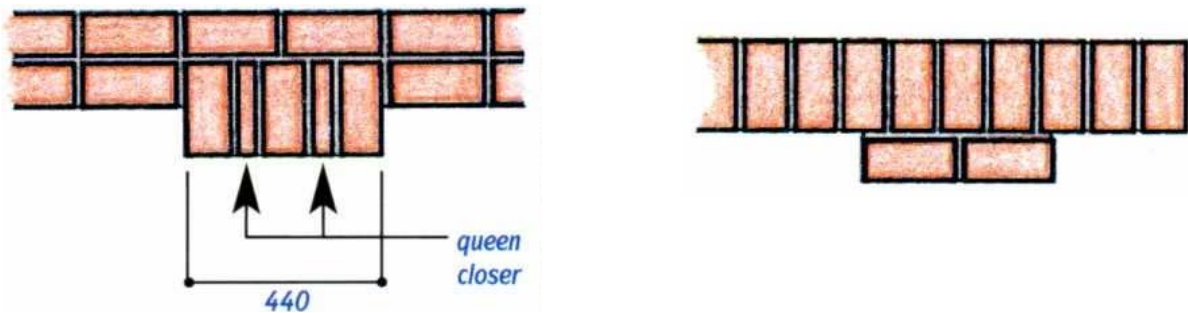

Piers – double attached

A correctly bonded thickening to both sides of the wall will provide additional strength. Remember to widen the foundation on both sides as shown earlier. The example illustrated is in English bond – considered to be the strongest of all bonds.

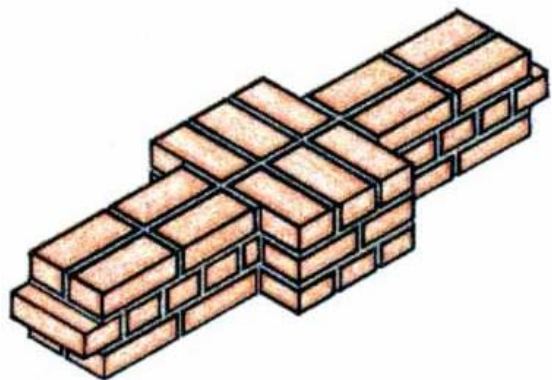

Pillars

One and a half by one and a half brick pillar to a one brick thick wall.

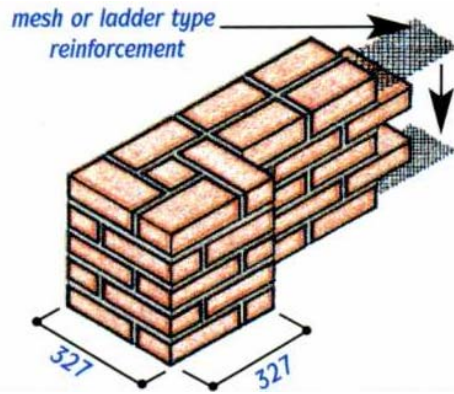

Pillars – gate carrying

Any gate will require a rigid support, the cantilever method of hanging increases the forces on the hangers. Timber gates will generally be heavier than open lattice wrought iron designs.

In the illustration on the left the central void can be filled with mortar. To avoid cement staining, the larger void on the right should ideally be treated with a liquid waterproofer before filling with concrete.

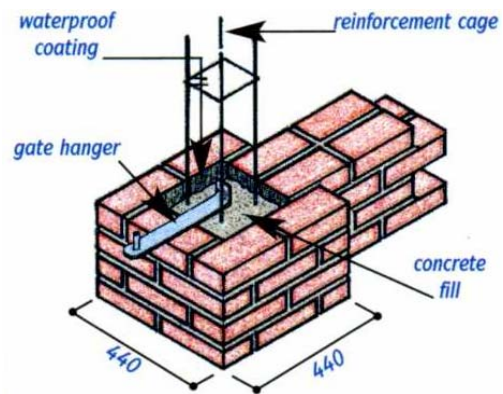
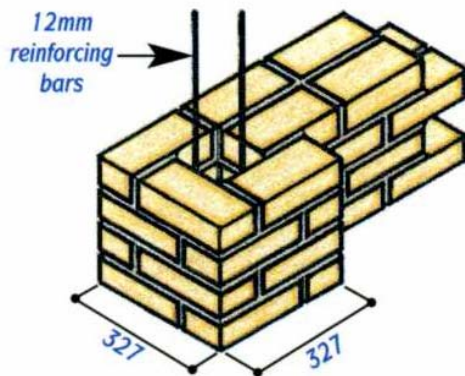

Cappings to piers

All copings and capping bricks must be of F2 S2 quality (frost resistant and low soluble salts).

The top of the wall is where water will ingress the brickwork in large quantities and the provision of a high bond flexible sheet dpc, either immediately beneath the capping/coping or a course further down, will do much to reduce the saturation of the walling beneath. Pillars and piers are no exception.

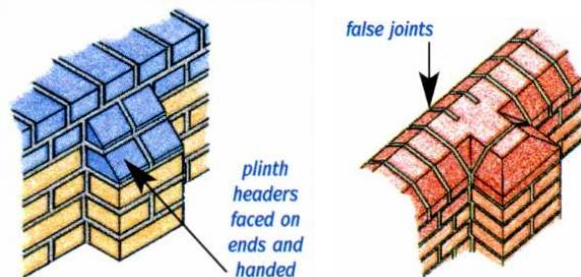

Cappings to pillars

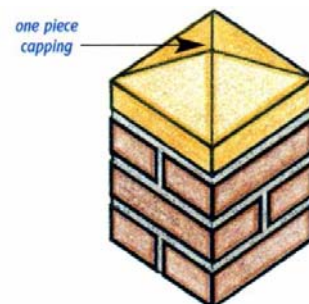
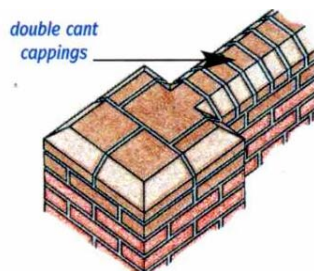
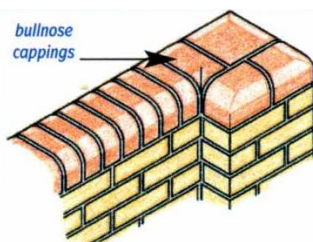

Copings to pillars

The use of a high bond dpc sandwiched between two layers of mortar is recommended.

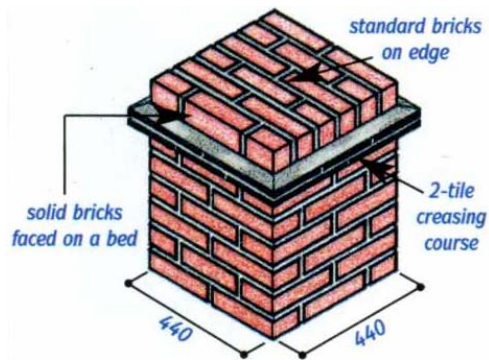

Not strictly a coping but quite effective if properly constructed.

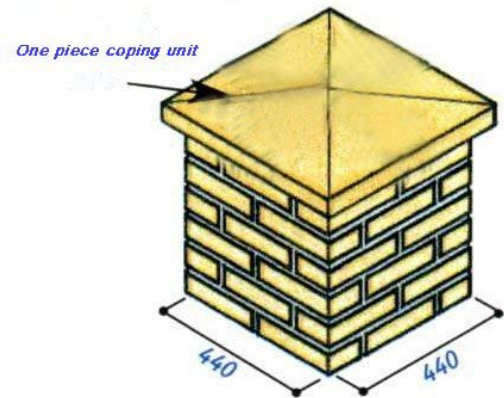

The ideal solution where coping units shed the water and incorporate an overhang and a drip groove (throating).

Damp-proof courses

Dpc's are barriers to the passage of water and moisture.

All dpc's to coping and capping courses must be 'high bond' types (the ability for mortar to stick to them) and they must be sandwiched within the mortar bed. This will mean a bed joint thickness of approximately 15mm.

Dpc's laid dry on one face of the brickwork provides a water and moisture barrier of sorts but no adhesive bond.